

CASE
CONSTRUCTION

F-SERIES WHEEL LOADERS

521F | 621F - SPEC SHEET

SCR
TECHNOLOGY



FASTER, FUEL EFFICIENT

A SAFE INVESTMENT FOR THE TOUGHEST JOBS

For the toughest jobs, reliability comes with a perfect control of the oil temperature in the axles.

- **For soft soil** where higher grip control and higher resistance are needed:
 - **Effective grip control** with the differential lock on the front axle. It can be activated automatically or manually controlled with the left foot.
 - **No overheating** because the differential lock does not slip
 - **Higher resistance** with heavy duty front and rear axles.
- **For a limited investment**, standard axles with limited slip differential are also available and proven to be reliable.
- **For even more reliability**, we have invented the COOLING BOX that keeps constant the cooling fluids temperature.



LESS MAINTENANCE, LOWER COSTS

- Lower costs because **SCR** uses fewer components:
 - No particulate filter
 - No extra fans for additional cooling
 - No specific oil needed
- Longer maintenance intervals:
 - because the engine oil is not contaminated with unfiltered air
- No break down: **SCR** offers the highest fuel compatibility

PREMIUM ENGINE TECHNOLOGY: SCR

SCR (Selective Catalytic Reduction) is a well-proven reliable solution. Having been in use in Europe since 2004 on trucks, the AdBlue™ DEF is can easily be found almost anywhere.

- More productivity with 10% fuel savings because SCR allows optimized combustion temperature
- No loss of power and fuel because no extra cooling is needed
- Cost savings, as SCR engines can be used with “red” fuel



MORE COMFORT FOR MORE PRODUCTIVITY



Access fit for a King

Getting in the cab is easy; the wide steps and the handle make you feel safe, while the wide door provides unobstructed access.

Outstanding visibility

You'll feel more confident and work faster with the great all round visibility.

The curved rear hood shape is very low because the **SCR technology** doesn't require additional fans for cooling.



All controls at your fingertips

Greater focus on the job and less stress with fewer arm moves thanks to the ergonomic positioning of the control panel under your right hand.

Feel confident with ROPS

All our wheel loaders' cab are reinforced and guarantee the operator protection against roll over (**ROPS certified**).



Great storage space

The overhead radio placement and the storage make the Case cab even more convenient for you



FASTER, FUEL EFFICIENT





THE DNA OF YOUR 521F

Productivity (50 meter distance cycle)

Considering density at 1.8 t/m³ and 100% fill factor
52 cycles/hour including 5 minute break _____ 52 loading cycles/h
with 2.1 m³ bucket _____ 110 m³/h or 180 t/h of material

Engine

Make _____ FPT engine F4HFE413J compliant with
Tier 4i EU regulations
Number of cylinders _____ 4 cylinders - 4.5 liters - common rail
Max power SAE J1995 _____ 106kW / 142 hp @1800 rpm
Maximum torque SAE J1349 _____ 608 Nm @1600 rpm
Nox emission _____ 2.88 g/kWh
HC emission _____ 0.08 g/kWh
CO emission _____ 2.64 g/kWh
PM emission _____ 0.013 g/kWh

Transmission

All-wheel drive with planetary axles
Kick-down function
4-speed torque converter
4-speed auto Powershift ZF type 4WG130, switchable to manual
shifting
forward speeds: 6-11-22-36 Km/h
reverse speeds: 6.4-12-23 Km/h
Adjustable transmission declutch

Axles and differential

- for outstanding traction with 50% longer maintenance intervals and 30% less tire wear:

100% auto-lock differential on front axle and open rear axles
Front and rear ZF heavy duty axles with open differential type MT-L3065-II

- for limited investment and good traction:

29% Limited slip differential on front and rear axles
front and rear axle ZF type MT-L3065-II

Tires

Tires _____ 17.5R25

Brakes

Service brake _____ Maintenance free, self-adjusting wet 4-wheel
disc brakes
Area _____ 0.31 m²/hub
Parking brake _____ Disc brake on transmission activated from the
cab cluster
Area _____ 58 cm²

Hydraulics

Valves _____ Rexroth Closed-center, Load sensing hydraulic system.
Main valve with 3 sections
Steering _____ The steering orbitrol hydraulically is actuated with
priority valve
Type of pump ___ Variable displacement pump (134 l/min @250 bar)
Automatic hydraulic functions
- Bucket Return-to-dig
- Boom Return-to-travel
- Auto.lift (to adjustable height)
Control type _____ Pilot control with single joystick or two levers

Capacities

Fuel tank _____ 189 usable liters
AdBlue tank _____ 41.3 usable liters
Cooling system _____ 22 liters
Engine oil _____ 12 liters
Hydraulic oil _____ Tank: 57 liters, total system: 114 liters
Transmission oil _____ 19 liters

Cab

For you safety the cab complies to:
protection against falling objects (FOPS) _____ ISO EN3449
protection against roll over (ROPS) _____ ISO EN13510

Noise and vibration

Interior noise _____ 72 dB(A) according to ISO6595/6396/3744
Exterior noise _____ 72 dB(A) at 15 meters as per SAE J88 SEP80
105 dB(A) according to ISO6595/6396/3744

Switchable reverse gear alarm

Vibrations _____ air-cushioned seat MSG 95A/732

Electrical

24 V. Batteries 2 x 12V.

Alternator _____ 70 A

521F Specifications

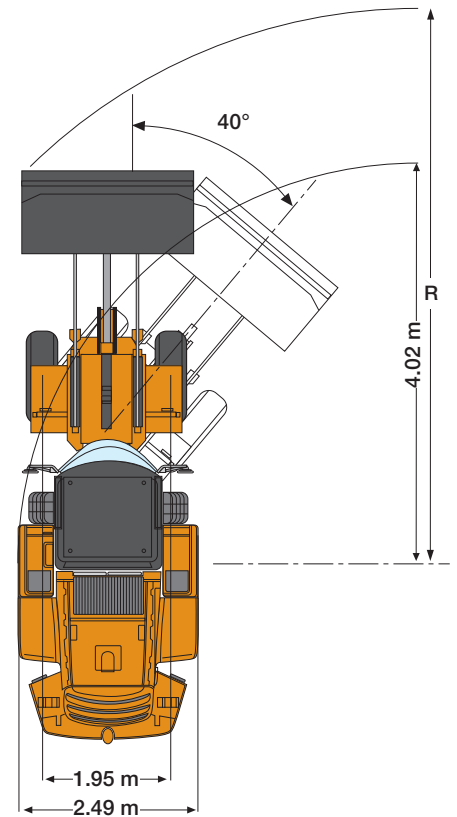
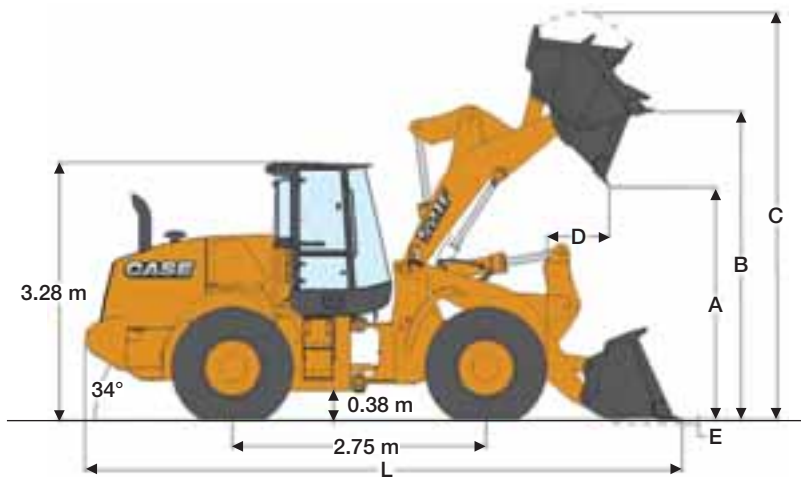

521F	Z-bar					Long Reach				XT	
	Bucket with bolt on :	2.1 m ³ bucket		1.7 m ³ bucket with quick coupler		1.9 m ³ bucket		1.7 m ³ bucket with quick coupler		1.7 m ³ bucket with quick coupler	
		edge	teeth + segment	edge	teeth	edge	teeth	edge	teeth	edge	teeth
Bucket volume (heaped)	m ³	2.07	2.07	1.70	1.70	1.88	1.84	1.70	1.70	1.70	1.70
Bucket Payload	kg	3478	3475	3535	3584	2977	2975	2947	2994	3249	3296
Maximum material density	ton/m ³	1.7	1.7	2.1	2.1	1.6	1.6	1.7	1.8	1.9	1.9
Bucket outside width	m	2.49	2.54	2.44	2.44	2.49	2.54	2.44	2.44	2.44	2.44
Bucket weight	kg	857	877	1137	1065	821	842	1137	1065	1117	1045
Tipping load - straight	kg	8150	8145	8317	8415	7011	7010	6985	7080	7634	7728
Tipping load - Articulated at 40°	kg	6957	6949	7069	7167	5955	5950	5894	5989	6497	6591
Breakout force	kg	7591	7781	7104	6959	8094	8366	7077	6933	8288	8124
Lift capacity from ground	kg	8889	8979	10620	10700	8830	8827	8689	8773	10236	10365
A - Dump height at 45° at full height	m	2.62	2.55	2.58	2.56	3.04	2.97	2.96	2.94	2.5	2.49
B - Hinge pin height	m	3.61	3.61	3.61	3.61	3.99	3.99	3.99	3.99	3.75	3.75
C - Overall height	m	4.75	4.75	4.77	4.77	5.06	5.06	5.14	5.14	4.94	4.94
D - Bucket reach at full height	m	1.12	1.19	1.18	1.22	1.05	1.12	1.16	1.19	1.23	1.27
E - Dig depth	cm	8	8	7	5	11	11	10	9	19	18
L - Overall length with bucket on the ground	m	6.83	6.94	6.90	6.92	7.11	7.21	7.24	7.27	7.05	7.07
R - Turning radius to front corner of the bucket	m	5.5	5.6	5.5	5.5	5.7	5.7	5.6	5.7	5.5	5.6
Bucket rollback in carry position	°	43	43	48	48	44	44	50	50	52	52
Dump angle at full height	°	55	55	50	50	51	51	46	46	62	62
Machine operating weight	kg	10448	10468	10728	10656	10582	10602	10897	10825	11189	11117

THE DNA OF YOUR 621F

Productivity (50 meter distance cycle)

Considering density at 1.8 t/m³ and 100% fill factor
52 cycles/hour including 5 minute break _____ 52 loading cycles/h
with 2.4 m³ bucket _____ 125 m³/h or 227 t/h of material

Engine

Make _____ FPT engine F4HFE613Z compliant with
Tier 4i EU regulations
Number of cylinders _____ 6 cylinders - 6.7 liters - common rail
Max power SAE J1995 _____ 128 kW / 172 hp @1800 rpm
Maximum torque SAE J1349 _____ 730 Nm @1600 rpm
Nox emission _____ 3.01 g/kWh
HC emission _____ 0.03 g/kWh
CO emission _____ 0.42 g/kWh
PM emission _____ 0.009 g/kWh

Transmission

All-wheel drive with planetary axles
4-speed auto Powershift ZF type 02G07135, switchable to manual
shifting
Adjustable transmission declutch
forward speeds: 7-13-24-39 Km/h
reverse speeds: 7-14-25 Km/h
Kick-down function

Axles and differential

- for outstanding traction with 50% longer maintenance
intervals and 30% less tire wear:
100% auto-lock differential on front axle and open rear axles
Front and rear ZF heavy duty axles with open differential and 100%
front lock
Type MT-L3075-II - dynamic load: 12.700kg
- for limited investment and good traction:
29% Limited slip differential on front and rear axles
Front heavy duty axle type MT-L3075-II - dynamic load: 12.700kg
Rear oscillating axle ZF type MT-3065-II rear - dynamic load
10.700kg

Tires

Tires _____ 20.5R25

Brakes

Service brake _____ Maintenance free, self-adjusting wet 4-wheel
disc brakes
Area _____ 0.39 m²/hub
Parking brake _____ Disc brake on transmission activated from the
cab cluster
Area _____ 58 cm²

Hydraulics

Valves _____ Rexroth Closed-center, Load sensing hydraulic system.
Main valve with 3 sections
Steering _____ The steering orbitrol hydraulically is actuated with
priority valve
Type of pump _____ Tandem Variable displacement pump
(171 l/min @250 bar)

Automatic hydraulic functions
- Bucket Return-to-dig
- Boom Return-to-travel
- Auto.lift (to adjustable height)
Control type _____ Pilot control with single joystick or two levers

Capacities

Fuel tank _____ 248 usable liters
AdBlue tank _____ 41.3 usable liters
Cooling system _____ 26.8 liters
Engine oil _____ 13 liters
Hydraulic oil _____ Tank: 91 liters, total system: 148 liters
Transmission oil _____ 27 liters

Cab

For you safety the cab complies to:
protection against falling objects (FOPS) _____ ISO EN3449
protection against roll over (ROPS) _____ ISO EN13510
Air flow _____ 8.5 m³ / min spread through 17 air vents

Noise and vibration

Driving noise in dB (A) 82 to SAE J88 @ 15 meters
Interior noise _____ 71 dB(A) as per ISO 6595/6396/3744
Exterior noise _____ 72 dB(A) at 15 meters as per SAE J88 SEP80
105dB (A) according to ISO 6595/6396/3744
Switchable reverse gear alarm
Vibrations _____ air-cushioned seat MSG 95A/732
average 1.4 m/s² as per ISO/TR 25398:2006

Electrical

24V. Batteries 2 x 12V.
Alternator _____ 65 A

621F Specifications

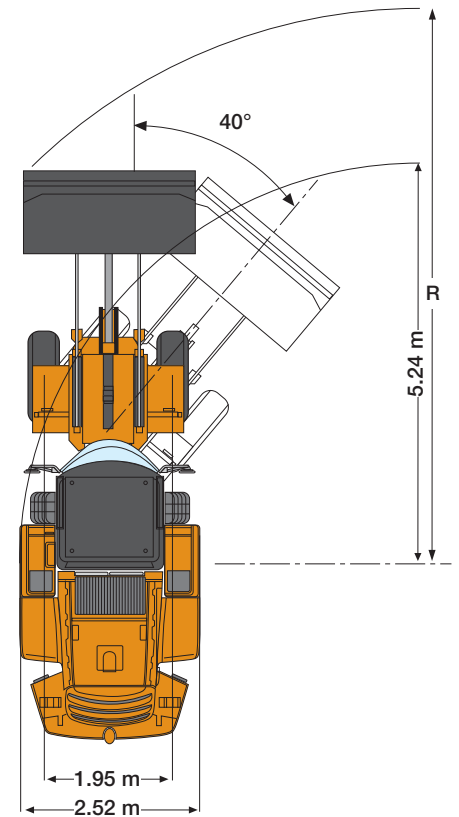
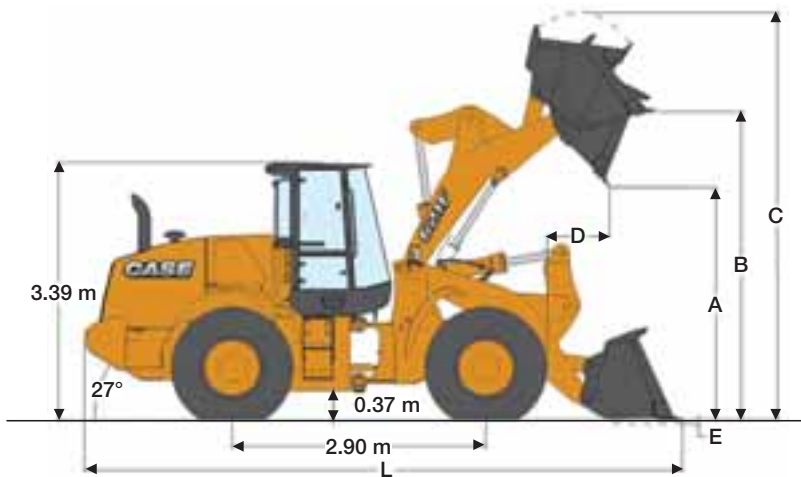

LOADER SPEED:

Raising time (loaded)	6.3 sec
Dump time (loaded)	1.2 sec
Lowering time (empty, power down)	4.4 sec
Lowering time (empty, float down)	4.4 sec

621F		Z-bar				Long Reach				XT	
		2.4 m ³ bucket		2.0 m ³ bucket with quick coupler		2.2 m ³ bucket		2.0 m ³ bucket with quick coupler		2.0 m ³ bucket with quick coupler	
		edge	teeth	edge	teeth	edge	teeth	edge	teeth	edge	teeth
Bucket volume (heaped)	m ³	2.38	2.36	2.00	2.00	2.18	2.14	2.00	2.00	2.00	2.00
Bucket Payload	kg	4371	4367	4519	4570	3707	3704	3708	3757	4092	4157
Maximum material density	ton/m ³	1.84	1.85	2.26	2.29	1.70	1.73	1.85	1.88	2.05	2.08
Bucket outside width	m	2.49	2.54	2.49	2.49	2.49	2.54	2.49	2.49	2.49	2.49
Bucket weight	kg	941	968	1242	1168	890	916	1242	1168	1242	1168
Tipping load - straight	kg	9964	9962	10325	10426	8488	8485	8527	8624	9360	9489
Tipping load - Articulated at 40°	kg	8741	8735	9038	9139	7414	7407	7416	7514	8185	8314
Breakout force	kg	9819	10097	9472	9272	11233	11591	9503	9310	10595	10395
Lift capacity from ground	kg	9857	9956	13068	13175	11411	11410	11348	11436	14642	14851
A - Dump height at 45° at full height	m	2.75	2.68	2.71	2.69	3.24	3.17	3.19	3.18	2.65	2.63
B - Hinge pin height	m	3.83	3.83	3.83	3.83	4.24	4.24	4.24	4.24	3.96	3.96
C - Overall height	m	5.04	5.04	5.05	5.05	5.45	5.45	5.46	5.46	5.23	5.23
D - Bucket reach at full height	m	1.08	1.16	1.12	1.16	1.01	1.01	1.22	1.25	1.23	1.26
E - Dig depth	cm	9	9	9	8	9	9	10	9	18	17
L - Overall length with bucket on the ground	m	7.47	7.57	7.53	7.56	7.75	7.86	7.93	7.97	7.78	7.81
Overall length without bucket	m	6.28	6.28	6.28	6.28	6.69	6.69	6.69	6.69	6.20	6.20
R - Turning radius to front corner of the bucket	m	5.7	5.8	5.7	5.7	5.9	6.0	5.9	5.9	5.8	5.8
Bucket rollback in carry position	°	44	44	49	49	46	46	51	51	58	58
Dump angle at full height	°	51	51	46	46	46	46	41	41	55	55
Machine operating weight	kg	12191	12218	12492	12418	12336	12362	12688	12614	12569	12459



Form No. 20016GB - Printed in Italy - MediaCross Firenze - 02/12

Worldwide Case Construction Equipment Contact Information

EUROPE:

via Plava, 80
10135 TORINO - ITALIA

AFRICA/MIDDLE EAST/CIS:

Riva Paradiso 14
6902 Paradiso - SWITZERLAND

NORTH AMERICA/MEXICO:

700 State Street
Racine, WI 53404 U.S.A.

LATIN AMERICA:

Av. General David Sarnoff 2237
32210 - 900 Contagem - MG
Belo Horizonte BRAZIL

ASIA PACIFIC:

Unit 1 - 1 Foundation Place - Prospect
New South Wales - 2148 AUSTRALIA

CHINA:

No. 29, Industrial Premises, No. 376,
De Bao Road, Waigaoqiao Ftz, Pudong,
SHANGHAI, 200131, P.R.C.

CASE Construction Equipment

CNH UK Ltd
Unit 4, Hayfield Lane Business Park,
Field Lane, Auckley, Doncaster,
DN9 3FL
Tel. 00800-2273-7373
Fax +44 1302 802829



CASE Customer Assistance
00800-2273-7373

The call is free from a land line. Check in advance with your Mobile Operator if you will be charged.



NOTE: Standard and optional fittings can vary according to the demands and specific regulations of each country. The illustrations may include optional rather than standard fittings - consult your Case dealer. Furthermore, CNH reserves the right to modify machine specifications without incurring any obligation relating to such changes.

Conforms to directive 98/37/CE

